

060355-10 Rev. B

May 2012

OmniSwitch 6250/6450 Transceivers Guide

Alcatel-Lucent 

www.alcatel-lucent.com

This user guide contains transceiver specifications and compatibility information for the OmniSwitch 6250/6450 switches. The information described in this guide is subject to change without notice.

Attention: Use of any transceivers other than those part numbers listed in the Compatibility Matrices is prohibited. Failure to comply with these matrices is not guaranteed for proper performance and may result in voiding the warranty for the affected platforms.

Copyright © 2012 by Alcatel-Lucent. All rights reserved. This document may not be reproduced in whole or in part without the express written permission of Alcatel-Lucent.

Alcatel-Lucent® and the Alcatel-Lucent logo are registered trademarks of Alcatel-Lucent. Xylan®, OmniSwitch®, OmniStack®, and Alcatel-Lucent OmniVista® are registered trademarks of Alcatel-Lucent.

OmniAccess™, Omni Switch/Router™, PolicyView™, RouterView™, SwitchManager™, VoiceView™, WebView™, X-Cell™, X-Vision™, and the Xylan logo are trademarks of Alcatel-Lucent.

This OmniSwitch product contains components which may be covered by one or more of the following U.S. Patents:

- U.S. Patent No. 6,339,830
- U.S. Patent No. 6,070,243
- U.S. Patent No. 6,061,368
- U.S. Patent No. 5,394,402
- U.S. Patent No. 6,047,024
- U.S. Patent No. 6,314,106
- U.S. Patent No. 6,542,507
- U.S. Patent No. 6,874,090



**26801 West Agoura Road
Calabasas, CA 91301
(818) 880-3500 FAX (818) 880-3505
esd.support@alcatel-lucent.com
US Customer Support—(800) 995-2696
Internet—service.esd@alcatel-lucent.com**

Contents

	About This Guide	v
	Supported Platforms	v
	Who Should Read this Manual?	vi
	When Should I Read this Manual?	vi
	What is Not in this Manual?	vi
	How is the Information Organized?	vii
	Documentation Roadmap	vii
	Related Documentation	ix
	Product Documentation	x
	Technical Support	x
Chapter 1	Small Form-Factor Pluggables (SFPs)	1-1
	In This Chapter	1-1
	SFP MSA Specification	1-2
	SFP Transceiver Installation and Removal	1-3
	Gigabit Ethernet Transceivers	1-5
	100 Mbit Ethernet Transceivers	1-10
	Dual-Speed Ethernet Transceivers	1-14
	10-Gigabit SFP+ Transceivers	1-15
Chapter 2	SFP Compatibility Matrix	1-18
	OmniSwitch 6250	1-18
	OmniSwitch 6450	1-19

About This Guide

This *OmniSwitch Transceivers Guide* provides specifications and compatibility information on the supported transceivers for the OmniSwitch 6250 and OmniSwitch 6450.

Supported Platforms

The information in this guide applies to the following products:

- OmniSwitch 6250
- OmniSwitch 6450

Unsupported Platforms

The information in this guide does not apply to the following products:

- OmniSwitch (original version with no numeric model name)
- OmniSwitch 6600 Series
- OmniSwitch 6800 Series
- OmniSwitch 7700/7800
- OmniSwitch 8800
- Omni Switch/Router
- OmniSwitch 6400 Series
- OmniSwitch 6850 Series
- OmniSwitch 6855 Series
- OmniSwitch 9000/9000E Series
- OmniStack 6200 Series
- OmniStack
- OmniAccess

Who Should Read this Manual?

The audience for this user guide is network administrators and IT support personnel who need to provide network connectivity using SFP transceivers on an OmniSwitch.

When Should I Read this Manual?

Read this guide as soon as you are ready to integrate your OmniSwitch into your network and you are ready to provide connectivity using the supported transceivers. You should have already stepped through the first login procedures and read the brief software overviews in the appropriate *OmniSwitch 6250/6450 Getting Started Guide* and *OmniSwitch 6250/6450 Hardware Guide*.

This guide includes information about the supported OmniSwitch transceivers.

- SFP specifications
- SFP compatibility information

What is Not in this Manual?

Procedures for switch management methods, such as CLI, web-based (WebView or OmniVista) or SNMP, are outside the scope of this guide.

For information on WebView and SNMP switch management methods consult the *OmniSwitch 6250/6450 Switch Management Guide*. Information on using WebView and OmniVista can be found in the context-sensitive on-line help available with those network management applications.

This guide is designed to provide transceiver specification and compatibility information only and is not intended as a reference for any CLI commands or configuration information. Refer to the Documentation Roadmap for a list of available user guides.

How is the Information Organized?

Chapters in this guide are broken down by transceiver type, SFP or XPF. Additional sub-sections are provided for the various types of transceivers.

Specification Information. Each transceiver has an associated table providing individual specifications for all supported transceivers.

Compatibility Information. A compatibility chart is provided for each transceiver specifying which modules or switch the transceiver is supported on.

Documentation Roadmap

The OmniSwitch user documentation suite was designed to supply you with information at several critical junctures of the configuration process. The following section outlines a roadmap of the manuals that will help you at each stage of the configuration process. Under each stage, we point you to the manual or manuals that will be most helpful to you.

Stage 1: Using the Switch for the First Time

Pertinent Documentation: *Getting Started Guides*
Release Notes

The *Getting Started Guide* provides the basic information you need to unpack and identify the components of your shipment. It provides information on unpacking the switch, unlocking access control, setting the switch's IP address, and setting up a password. It also includes overview information on fundamental aspects of the switch, such as hardware LEDs, the software directory structure, CLI conventions, and web-based management.

At this time you should also familiarize yourself with the Release Notes that accompanied your switch. This document includes important information on feature limitations that are not included in other user guides.

Stage 2: Gaining Familiarity with Basic Switch Functions

Pertinent Documentation: *Hardware Users Guides*
Switch Management Guide
OmniSwitch Transceivers Guide

Once you have your switch up and running, you will want to begin investigating basic aspects of its hardware and software. Information about switch hardware is provided in the *Hardware Guide*. This guide provides specifications, illustrations, and descriptions of all hardware components, such as chassis, power supplies, Chassis Management Modules (CMMs), Network Interface (NI) modules, and cooling fans. It also includes steps for common procedures, such as removing and installing switch components.

The *Switch Management Guide* is the primary users guide for the basic software features on a single switch. This guide contains information on the switch directory structure, basic file and directory utilities, switch access security, SNMP, and web-based management. It is recommended that you read this guide before connecting your switch to the network.

Stage 3: Integrating the Switch Into a Network

Pertinent Documentation: *Network Configuration Guide*

When you are ready to connect your switch to the network, you will need to learn how the OmniSwitch implements fundamental software features, such as 802.1Q, VLANs, Spanning Tree, and network routing protocols. The *Network Configuration Guide* contains overview information, procedures, and examples on how standard networking technologies are configured in the OmniSwitch.

Anytime

The *OmniSwitch CLI Reference Guide* contains comprehensive information on all CLI commands supported by the switch. This guide includes syntax, default, usage, example, related CLI command, and CLI-to-MIB variable mapping information for all CLI commands supported by the switch. This guide can be consulted anytime during the configuration process to find detailed and specific information on each CLI command.

Related Documentation

The following are the titles and descriptions of all the related OmniSwitch AOS Release 6 user manuals:

- *OmniSwitch 6250 Getting Started Guide*

Describes the basic information you need to unpack and identify the components of your OmniSwitch shipment. Also provides information on the initial configuration of the switch.

- *OmniSwitch 6250 Hardware Users Guide*

- Detailed technical specifications and procedures for the chassis and components. Also includes comprehensive information on assembling and managing stacked configurations.

- *OmniSwitch 6450 Getting Started Guide*

Describes the basic information you need to unpack and identify the components of your OmniSwitch shipment. Also provides information on the initial configuration of the switch.

- *OmniSwitch 6450 Hardware Users Guide*

Detailed technical specifications and procedures for the chassis and components. Also includes comprehensive information on assembling and managing stacked configurations.

- *OmniSwitch 6250/6450 CLI Reference Guide*

Complete reference to all CLI commands supported on the OmniSwitch Series switches. Includes syntax definitions, default values, examples, usage guidelines and CLI-to-MIB variable mappings.

- *OmniSwitch 6250/6450 Switch Management Guide*

Includes procedures for readying an individual switch for integration into a network. Topics include the software directory architecture, image rollback protections, authenticated switch access, managing switch files, system configuration, using SNMP, and using web management software (WebView).

- *OmniSwitch 6250/6450 Network Configuration Guide*

Includes network configuration procedures and descriptive information on all the major software features and protocols included in the base software package. Chapters cover Layer 2 information (Ethernet and VLAN configuration), Layer 3 information (routing protocols, such as RIP), security options (authenticated VLANs), Quality of Service (QoS), and link aggregation.

- *OmniSwitch 6250/6450 Transceivers Guide*

Includes transceiver specifications and product compatibility information.

- *Technical Tips, Field Notices*

Includes information published by Alcatel-Lucent's Customer Support group.

- *Release Notes*

Includes critical open Problem Reports, feature exceptions, and other important information on the features supported in the current release and any limitations to their support.

Product Documentation

All products are shipped with a Product Documentation Card that provides details for downloading documentation for all OmniSwitch and other Alcatel-Lucent data enterprise products.

All documentation is in PDF format and requires the Adobe Acrobat Reader program for viewing. Acrobat Reader freeware is available at www.adobe.com.

Note. When printing pages from the documentation PDFs, de-select Fit to Page if it is selected in your print dialog. Otherwise pages may print with slightly smaller margins.

Technical Support

An Alcatel-Lucent service agreement brings your company the assurance of 7x24 no-excuses technical support. You'll also receive regular software updates to maintain and maximize your Alcatel-Lucent product's features and functionality and on-site hardware replacement through our global network of highly qualified service delivery partners. Additionally, with 24-hour-a-day access to Alcatel-Lucent's Service and Support web page, you'll be able to view and update any case (open or closed) that you have reported to Alcatel-Lucent's technical support, open a new case or access helpful release notes, technical bulletins, and manuals. For more information on Alcatel-Lucent's Service Programs, see our web page at service.esd.alcatel-lucent.com, call us at 1-800-995-2696, or email us at esd.support@alcatel-lucent.com.

1 Small Form-Factor Pluggables (SFPs)

OmniSwitch switches use both copper-based and fiber-based optical Small Form Factor Pluggable (SFP) transceivers. SFPs are fully hot-swappable and are available for both short-reach and long-reach applications. Copper-based and fiber-based optical SFPs can be mixed on the same module.

In This Chapter

This chapter describes the technical specifications for all the OmniSwitch supported SFP transceivers. For additional details about OmniSwitch modules, see the appropriate *OmniSwitch Hardware Guide*.

SFP specifications in this chapter include:

- SFP MSA Specifications. See [“SFP MSA Specification”](#) on page 1-2
- SFP Transceiver Installation. See [“SFP Transceiver Installation and Removal”](#) on page 1-3
- Gigabit Ethernet Transceivers. See [“Gigabit Ethernet Transceivers”](#) on page 1-5.
- 100 Mbit Ethernet Transceivers. See [“100 Mbit Ethernet Transceivers”](#) on page 1-10.
- Dual-Speed Ethernet Transceivers. See [“Dual-Speed Ethernet Transceivers”](#) on page 1-14.
- 10-Gigabit SFP+ Transceivers. See [“10-Gigabit SFP+ Transceivers”](#) on page 1-15

For information on installing and managing OmniSwitch hardware, see the appropriate *Hardware Users Guide*.

For information on OmniSwitch SFP compatibility, see [“SFP Compatibility Matrix”](#) on page 2-18.

SFP MSA Specification

The Small Form-Factor Pluggable (SFP) MSA (Multi Source Agreement) is a specification for a common interface for optical modular transceivers. The SFP connector consists of a 20-pin receptacle and an SFP housing cage. The connector provides the interface for the hot pluggable SFP module. Each SFP module contains a serial interface to provide identification information that describes the SFP capabilities, stand interfaces, manufacturer and other information.

For information on installing SFPs, refer to the documentation included with the transceiver.

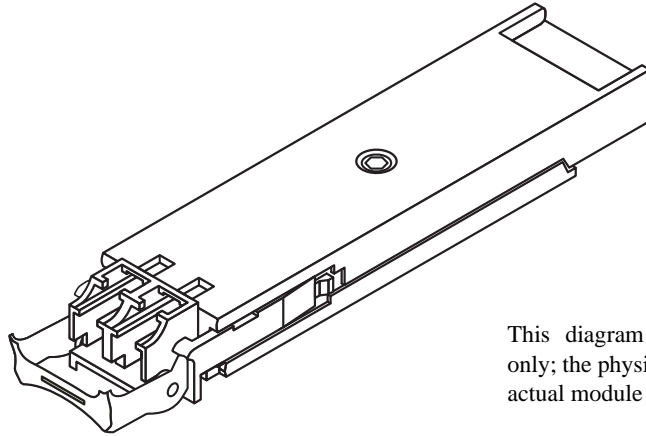

This diagram is a representation only; the physical appearance of the actual module may vary slightly.

Small Form Factor Pluggable (SFP)

SFP Transceiver Installation and Removal

Follow the instructions below for the appropriate SFP type.

ESD Caution: Before handling the module, you must discharge all static electricity on your person to avoid Electrostatic Discharge (ESD) damage. If using a wrist strap, ensure that the wrist strap touches your skin. Attach the other end of the strap to the chassis. If your chassis provides a grounding lug, this can be used. Refer to your Hardware Users Guide for details.

If using a wrist strap, ensure that the wrist strap touches your skin. Attach the other end of the strap to the chassis. If your chassis provides a grounding lug, this can be used. Refer to your Hardware Users Guide for details.

Dust Exposure: To reduce the risk of dust exposure and physical damage, be sure to replace the protective rubber cover (provided) when the SFP is not in use.

Eye Safety: SFP transceivers are international Class 1 laser products and are eye-safe devices *when operated within the limits of manufacturers' specifications*. Operating SFP transceivers in a manner inconsistent with intended usage and specification may result in hazardous radiation exposure.

Note: After removing a transceiver, wait for a minimum of 5 seconds before re-inserting any transceiver into the same port. This allows sufficient time for software to detect the removal of the transceiver. *Never force the transceiver in or out of the transceiver slot.*

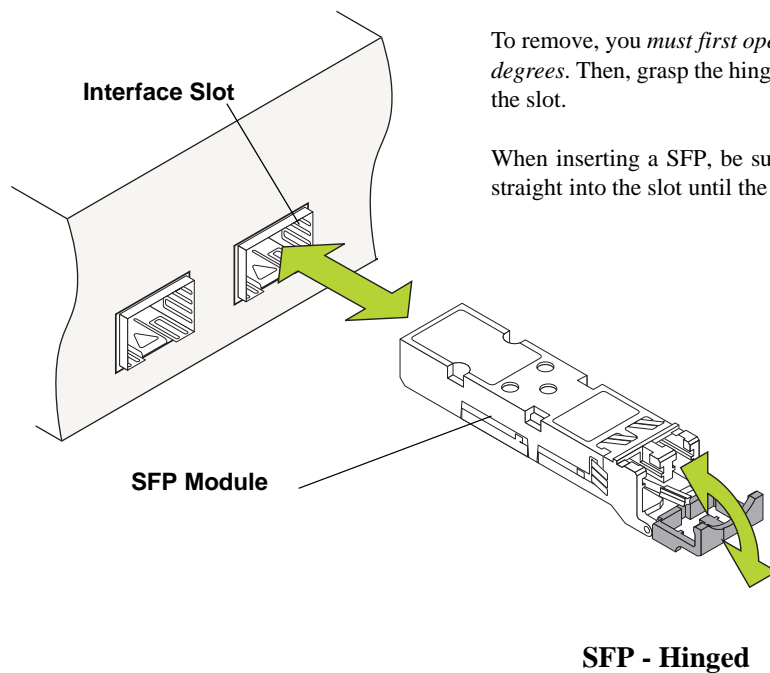

To remove, you *must first open the SFP's hinged face to approximately ninety degrees*. Then, grasp the hinged face and carefully pull the SFP *straight* out of the slot.

When inserting a SFP, be sure that the hinged face is *closed*. Slide the SFP straight into the slot until the module clicks firmly into place.

To install, align the transceiver with the transceiver slot on the NI module, as shown. Be sure that the bail wire delatch is in the *up, or closed position*. Slide the transceiver straight into the slot until the module clicks firmly into place.

To remove, you must first pull down on the bail wire delatch. Grip the wire delatch while it is in this open position and carefully pull the transceiver straight out of the slot.

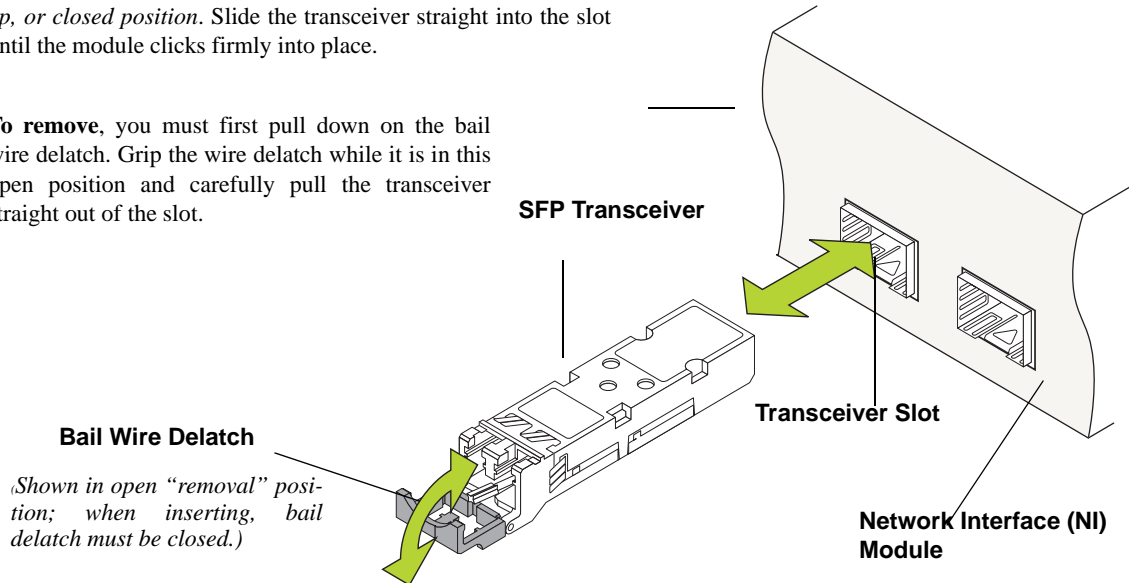

SFP - Bail Wire

To install, align the transceiver with the transceiver slot on the NI module, as shown. Carefully slide the transceiver back until it clicks into place; this is an indication that the connectors are firmly seated.

To remove, use the ejector tool (provided with each switch chassis) to push the transceiver's ejector button. The ejector button is located just below the transceiver port; refer to the diagram for more information. The transceiver will disengage from the connectors and eject slightly. Once disengaged, *use the clip end of the ejector tool* to carefully pull the transceiver straight out and away from the NI module.

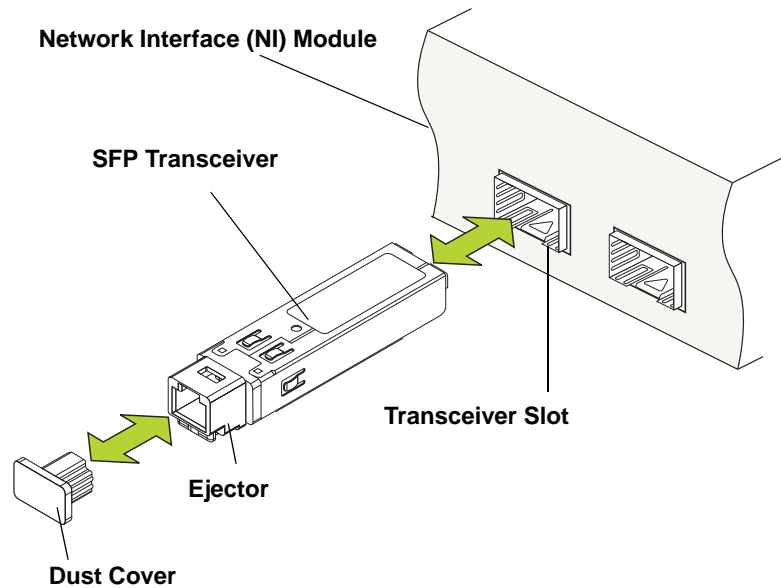

SFP - Ejector Button

Gigabit Ethernet Transceivers

SFP-GIG-SX

Gigabit SFP Optical Transceiver.

Connector Type	LC
Standards Supported	802.3z, SFP MSA
Connections Supported	1000Base-SX
Fiber Type	MMF
Wavelength	850 nm
Optical Power Output	-9.5 to -4 dBm
Receiver Sensitivity	-17 dBm
Transmission Distance	~275 m on 62.5/125 μ m ~550 m on 50/125 μ m
Operating Temperature	0 °C to 70 °C
Digital Diagnostic Monitoring	Not Supported

SFP-GIG-LX

Gigabit SFP Optical Transceiver.

Connector types	LC
Standards supported	802.3z, SFP MSA
Connections supported	1000Base-LX
Fiber Type	SMF
Wavelength	1310 nm
Optical Power Output	-9.5 to -3 dBm
Receiver Sensitivity	-20 dBm
Transmission Distance	~10 km
Operating Temperature	-40 °C to 85 °C / 0 °C to 70 °C
Digital Diagnostic Monitoring	Not Supported

SFP-GIG-LH40

Gigabit SFP Optical Transceiver.

Connector Type	LC
Standards Supported	802.3z, SFP MSA
Connections Supported	1000Base-LH40
Fiber Type	SMF
Wavelength	1310 nm
Optical Power Output	-2 to +3 dBm
Receiver Sensitivity	-22 dBm
Transmission Distance	~40 km
Operating Temperature	0 °C to 70 °C
Digital Diagnostic Monitoring	Supported

SFP-GIG-LH70

Gigabit SFP Optical Transceiver.

Connector Type	LC
Standards Supported	802.3z, SFP MSA
Connections Supported	1000Base-LH70
Fiber Type	SMF
Wavelength	1550 nm
Optical Power Output	0 to +5 dBm
Receiver Sensitivity	-22 dBm
Transmission Distance	~70 km
Operating Temperature	0 °C to 70 °C
Digital Diagnostic Monitoring	Supported

SFP-GIG-EXTND

Gigabit SFP Optical Transceiver.

Connector Type	LC
Standards Supported	802.3z, SFP MSA
Connections Supported	1000Base-SX
Fiber Type	MMF
Wavelength	850 nm
Optical Power Output	-
Receiver Sensitivity	-
Transmission Distance	~2 km
Operating Temperature	0 °C to 70 °C
Digital Diagnostic Monitoring	Supported

SFP-GIG-T

Gigabit SFP Copper Transceiver.

Connector Type	RJ-45
Standards Supported	802.3z, SFP MSA
Connections supported	10/100/1000Base-T
Cable Type	CAT5, CAT5e, CAT6
Transmission Distance	~100 m
Digital Diagnostic Monitoring	Not Supported

SFP-GIG-BX-D

Bi-Directional SFP Optical Transceiver.

Connector Type	LC
Standards Supported	802.3ah, SFP MSA
Connections Supported	1000Base-BX10
Fiber Type	SMF
Wavelength	Transmit: 1490 nm Receive: 1310 nm
Average Power Output	-9 to -3 dBm
Receiver Sensitivity	-19.5 dBm
Transmission Distance	~10 km
Operating Temperature	0 °C to 70 °C
Digital Diagnostic Monitoring	Supported
Notes	Designed for use with SFP-GIG-BX-U

SFP-GIG-BX-U

Bi-Directional SFP Optical Transceiver.

Connector Type	LC
Standards Supported	802.3ah, SFP MSA
Connections Supported	1000Base-BX10
Fiber Type	SMF
Wavelength	Transmit: 1310 nm Receive: 1490 nm
Average Power Output	-9 to -3 dBm
Receiver Sensitivity	-19.5 dBm
Transmission Distance	~10 km
Operating Temperature	0 °C to 70 °C
Digital Diagnostic Monitoring	Supported
Notes	Designed for use with SFP-GIG-BX-D

SFP-GIG-CWD

Coarse Wavelength Division Multiplexing (CWDM) is an optical transceiver supporting single-mode fiber over various wavelengths. CWDMs are hot-pluggable and are available for long-reach applications.

Connector Type	LC
Standards Supported	802.3z, SFP MSA
Connections Supported	1000Base-LX
Fiber Type	SMF
Wavelength	1470, 1490, 1510, 1530, 1550, 1570, 1590, 1610
Optical Power Output	-2 to +3 dBm
Receiver Sensitivity	-24 dBm
Transmission Distances	~62 km
Operating Temperature	-5 °C to 70 °C
Digital Diagnostic Monitoring	Not Supported

100 Mbit Ethernet Transceivers

SFP-100-BX20LT

Bi-Directional SFP Optical Transceiver.

Connector Type	SC
Standards Supported	802.3ah, SFP MSA, ITU-T G.983
Connections Supported	100Base-BX
Fiber Type	SMF
Wavelength	Transmit: 1550 nm Receive: 1310 nm
Average Power Output	-14 to -8 dBm
Receiver Sensitivity	-32 dBm
Transmission Distance	~20 km
Operating Temperature	0 °C to 70 °C
Digital Diagnostic Monitoring	Supported
Notes	Designed for use with SFP-100-BX20NU

SFP-100-BX20NU

Bi-Directional SFP Optical Transceiver.

Connector Type	SC
Standards Supported	802.3ah, SFP MSA, ITU-T G.983
Connections Supported	100Base-BX
Fiber Type	SMF
Wavelength	Transmit: 1310 nm Receive: 1550 nm
Average Power Output	-14 to -8 dBm
Receiver Sensitivity	-32 dBm
Transmission Distance	~20 km
Operating Temperature	0 °C to 70 °C
Digital Diagnostic Monitoring	Supported
Notes	Designed for use with SFP-100-BX20LT

SFP-100-BXLC-D

Bi-Directional SFP Optical Transceiver.

Connector Type	LC
Standards Supported	802.3ah, SFP MSA, ITU-T G.983
Connections Supported	100Base-BX
Fiber Type	SMF
Wavelength	Transmit: 1550 nm Receive: 1310 nm
Average Power Output	-14 to -8 dBm
Receiver Sensitivity	-32 dBm
Transmission Distance	~20 km
Operating Temperature	0 °C to 70 °C
Digital Diagnostic Monitoring	Supported
Notes	Designed for use with SFP-100-BXLC-U

SFP-100-BXLC-U

Bi-Directional SFP Optical Transceiver.

Connector Type	LC
Standards Supported	802.3ah, SFP MSA, ITU-T G.983
Connections Supported	100Base-BX
Fiber Type	SMF
Wavelength	Transmit: 1310 nm Receive: 1550 nm
Average Power Output	-14 to -8 dBm
Receiver Sensitivity	-32 dBm
Transmission Distance	~20 km
Operating Temperature	0 °C to 70 °C
Digital Diagnostic Monitoring	Supported
Notes	Designed for use with SFP-100-BXLC-D

SFP-100-LC-MM

SFP Optical Transceiver.

Connector Type	LC
Standards Supported	802.3u, SFP MSA
Connections supported	100Base-FX
Fiber Type	MMF
Wavelength	1310 nm
Optical Power Output	-19 to -14 dBm on 62.5/125 μ m -22 to -14 dBm on 50/125 μ m
Transmission Distance	~2 km on 62.5/125 μ m ~2 km on 50/125 μ m
Operating Temperature	0 °C to 70 °C
Digital Diagnostic Monitoring	Not Supported

SFP-100-LC-SM15

SFP Optical Transceiver.

Connector Type	LC
Standards Supported	802.3u, SFP MSA
Connections Supported	100Base-FX
Fiber Type	SMF
Wavelength (nm)	1310 nm
Optical Power Output	-15 to -8 dBm
Receiver Sensitivity	-34 dBm
Transmission Distance	~15 km
Operating Temperature	0 °C to 70 °C
Digital Diagnostic Monitoring	Not Supported

SFP-100-LC-SM40

SFP Optical Transceiver.

Connector Type	LC
Standards Supported	802.3u, SFP MSA
Connections Supported	100Base-FX
Fiber Type	SMF
Wavelength	1310 nm
Optical Power Output	-15 to -8 dBm
Receiver Sensitivity	-34 dBm
Transmission Distances	~40 km
Operating Temperature	0 °C to 70 °C
Digital Diagnostic Monitoring	Not Supported

Dual-Speed Ethernet Transceivers

SFP-DUAL-BX-D

Dual-Speed Bi-Directional SFP Optical Transceiver.

Connector Type	LC
Standards Supported	802.3z, SFP MSA
Connections Supported	1000BASE-BX10-D
Fiber Type	SMF
Wavelength	Transmit: 1550 nm Receive: 1310 nm
Average Power Output	-9 to -3 dBm
Receiver Sensitivity	-18.7 dBm
Transmission Distance	~ 10 km
Operating Temperature	0 °C to 70 °C
Digital Diagnostic Monitoring	Not Supported

SFP-DUAL-BX-U

Dual-Speed Bi-Directional SFP Optical Transceiver.

Connector Type	LC
Standards Supported	802.3z, SFP MSA
Connections Supported	1000BASE-BX10-U
Fiber Type	SMF
Wavelength	Transmit: 1310 nm Receive: 1550 nm
Average Power Output	-9 to -3 dBm
Receiver Sensitivity	-18.7 dBm
Transmission Distances	~ 10 km
Operating Temperature	0 °C to 70 °C
Digital Diagnostic Monitoring	Not Supported

10-Gigabit SFP+ Transceivers

SFP-10G-SR

10-Gigabit SFP+ Optical Transceiver.

Connector Type	LC
Standards Supported	802.3 Clause 52
Connections supported	10GBase-SR
Fiber Type	MMF
Wavelength	850 nm
Optical Power Output	-7.3 to -1.3 dBm
Receiver Sensitivity	-11.1 dBm
Transmission Distance	~ 300 m
Operating Temperature	0 °C to 70°C
Digital Diagnostic Monitoring	Supported

SFP-10G-LR

10-Gigabit SFP+ Optical Transceiver.

Connector Type	LC
Standards Supported	802.3 Clause 52
Connections supported	10GBase-LR
Fiber Type	SMF
Wavelength	1310 nm
Optical Power Output	-8.2 to 0.5 dBm
Receiver Sensitivity	-12.6 dBm
Transmission Distance	~ 10 km
Operating Temperature	0 °C to 70°C
Digital Diagnostic Monitoring	Supported

SFP-10G-ER

10-Gigabit SFP+ Optical Transceiver.

Connector Type	LC
Standards Supported	802.3ae
Connections supported	10GBase-E
Fiber Type	SMF
Wavelength	1550 nm
Optical Power Output	-4.7 to 4.0 dBm
Receiver Sensitivity	-14.1 dBm
Transmission Distance	~ 40 km
Operating Temperature	0 °C to 70 °C
Digital Diagnostic Monitoring	Supported

SFP-10G-LRM

10-Gigabit SFP+ Optical Transceiver.

Connector Type	LC
Standards Supported	802.3aq
Connections supported	10GBase-LRM
Fiber Type	MMF
Wavelength	1310 nm
Optical Power Output	-6.5 to .5 dBm
Receiver Sensitivity	-6.5 dBm
Transmission Distance	~ 220 m
Operating Temperature	0 °C to 70°C
Digital Diagnostic Monitoring	Supported

SFP-10G-C

10-Gigabit SFP+ Copper Transceiver.

Connector Type	Direct Attached
Standards Supported	802.3ae
Cable Length	60cm, 1m, 3m, 7m ¹
Wire Gauge	24AWG
Bend Radius	1.25 in.
Digital Diagnostic Monitoring	Not Supported

¹ Check for availability of lengths.

2 SFP Compatibility Matrix

OmniSwitch 6250

The following table shows the Ethernet transceiver configurations and the minimum release required for support on the OmniSwitch 6250:

SFP	OS6250
SFP-GIG-SX	6.6.1
SFP-GIG-LX	6.6.1
SFP-GIG-LH40	6.6.1
SFP-GIG-LH70	6.6.1
SFP-GIG-EXTND	6.6.1
SFP-GIG-T	6.6.1
SFP-GIG-BX-D	6.6.1
SFP-GIG-BX-U	6.6.1
SFP-GIG-CWD	Not Supported
SFP-100-BX20LT ¹	6.6.1
SFP-100-BX20NU ¹	6.6.1
SFP-100-BXLC-D ¹	6.6.1
SFP-100-BXLC-U ¹	6.6.1
SFP-100-LC-MM ¹	6.6.1
SFP-100-LC-SM15 ¹	6.6.1
SFP-100-LC-SM40 ¹	6.6.1
SFP-DUAL-BX-D	Not Supported
SFP-DUAL-BX-U	Not Supported
SFP-10G-SR	Not supported
SFP-10G-LR	Not supported
SFP-10G-ER	Not supported
SFP-10G-LRM	Not supported
SFP-10G-C	Not supported

1. Only supported on combo ports @ 100Mbps speed.

OmniSwitch 6450

The following table shows the Ethernet transceiver configurations and the minimum release required for support on the OmniSwitch 6450:

SFP	OS6450
SFP-GIG-SX	6.6.3
SFP-GIG-LX	6.6.3
SFP-GIG-LH40	6.6.3
SFP-GIG-LH70	6.6.3
SFP-GIG-EXTND	Not Supported
SFP-GIG-T¹	6.6.3
SFP-GIG-BX-D	6.6.3
SFP-GIG-BX-U	6.6.3
SFP-GIG-CWD	6.6.3
SFP-100-BX20LT²	6.6.3
SFP-100-BX20NU²	6.6.3
SFP-100-BXLC-D²	6.6.3
SFP-100-BXLC-U²	6.6.3
SFP-100-LC-MM²	6.6.3
SFP-100-LC-SM15²	6.6.3
SFP-100-LC-SM40²	6.6.3
SFP-DUAL-BX-D	6.6.3
SFP-DUAL-BX-U	6.6.3
SFP-10G-SR	6.6.3
SFP-10G-LR	6.6.3
SFP-10G-ER	6.6.3
SFP-10G-LRM	6.6.3
SFP-10G-C	6.6.3

1. 6450-U24 supports 10/100/1000 on user ports and combo ports. All models 1G/10G uplink ports and expansion modules support 1G speed.

2. Supported on 6450-U24 user ports and combo ports. Not supported on 1G/10G uplink ports or expansion modules.

